

WINGNUT WINGS



Junkers J.1

1/32 Scale

In late 1916 Idflieg (the German Inspectorate of Aviation Troops) issued the J type design specification for an armoured ground attack and army liaison aircraft. Junkers responded with one of the most revolutionary aircraft of World War One, the Junkers J.1.

Junkers were a pioneer in the construction of metal aircraft with their steel monoplane (confusingly also called the J.1) being completed in 1915. This was followed by an improved version called the J.2 and finally the J.3 made from the much lighter duraluminium (aluminium). This material was the natural choice for use in Hugo Junkers' revolutionary J.4 designed to meet Idflieg's J type specifications. This J.4, as Junkers referred to it, was confusingly designated the J.1 in service by Idflieg.

The Junkers J.1 (J.4) airframe was constructed entirely of duraluminium (dural) tubes almost completely sheathed in corrugated dural sheet. The front fuselage was constructed from 5mm armoured steel to protect the crew from enemy fire. Initially the rear fuselage, fin and rudder were covered with fabric but later production aircraft had the fin and rudder sheathed in corrugated sheet dural. Development was continued post armistice when even the rear fuselage was covered with corrugated sheet dural. This fully corrugated aircraft design would remain a Junkers feature well into the 1930s.

Nicknamed 'the flying tank' or 'removal van', the Junkers J.1 was the A-10 Thunderbolt of its day, designed to attack enemy ground targets while remaining impervious to ground fire. Despite being heavy, relatively slow and requiring a long take off and landing area, the J.1 was popular with its crews due to the protection provided by its armoured front section and all metal airframe.

WW1 aircraft colours are contentious at the best of times and we have done our best to provide what we consider to be accurate painting information for this aircraft. Period reports indicate that the Junkers J.1 was painted in pale green on the upper surfaces, with darker green struts and undercarriage. The undersides were painted a very pale blue. Many aircraft had mauve camouflage applied to the upper surfaces in a wide variety of patterns. The armoured steel front section appears to have sometimes been left in red oxide primer (appearing very dark in period photos). At some stage there has been an attempt to disguise the all metal undersurface by painting it in a pale sand colour to represent the clear doped linen of less aggressive aircraft. Initially this appears to have been applied quite roughly over the pale blue in the field before being adopted as standard at the factory. Later aircraft had their fabric surfaces covered in pre-printed 5 colour lozenge camouflage material.

Wingspan:	Length:	Max Weight:	Max Speed:
16.00m (52.5 ft)	9.06m (29.7 ft)	2176 kg (4797 lb)	155 kph (96.3 mph)
No. manufactured:	Production:	Engine:	
227	May 1917 to Jan. 1919	Benz Bz.IV	
Armament:			
7.92mm (0.311 in) Parabellum LMG14 or LMG14/17 machine gun, Stick Grenades; Bombs			
References:			
Windsock Datafile 39 Junkers J.1 by P.M.Grosz 1993 - Canada Aviation Museum, Ottawa, Canada. Deutsches Technikmuseum, Berlin, Germany. - 1914-1918 Aviation Heritage Trust - Private Collections.			

Junkers J.1

1/32 Scale













Warning: Choking hazard. Keep small parts and plastic bags away from children. Use glue and paint in a well ventilated area. Always wear protective eyewear when cutting and a protective mask when painting, gluing and sanding. Do not breathe dust from polyurethane resin parts (if included). Beware of sharp edges on metal parts.

Assembly: Read all the instructions carefully before starting assembly. Use glue intended for plastic models. Assemble metal and resin parts (if included) using Cyanoacrylate (CA) or epoxy glue. Before assembly select a marking option and note optional parts required in instructions.

Painting: Only use paints suitable for plastic model kits.

Decals: Cut out each decal as required. Soak in warm water for 15 seconds. Slide off backing paper onto gloss painted surface of model. For large decals it is helpful to apply a drop of water to the area they are being applied to. This will make it easier to maneuver them into the correct position

SYMBOLS

 Construction Step	 Choose	 Attention	 Remove
 Part Number	 Do Not Cement	 Option	 Drill
 Decal	 Cement For Metal	 Other Side	 Paint Colour
 Photo Etch Part			

PAINT COLOURS

	All colours	Tamiya	Humbrol	Misterkit
a	Brass	X12	54	
b	Copper	XF6	12	
c	Gun metal	X10	27004	
d	Aluminium	XF16	27001	
e	Matt Black	XF1	33	
f	Dark Brown	XF68	98	
g	Dark Grey-Green	XF67	117	GC05
h	Leather	XF52	62	
i	Light Blue	XF23(x1) + XF2(x1)	65	GC09
j	Light Grey	XF12	64	
k	Medium Grey-Green	XF71	78	GC04
l	Matt Red	XF7	60	
m	Matt Rust	XF9	113	
n	Matt White	XF2	34	
o	Matt Wood	XF59	110	
p	Mauve	X16(x2) + XF52(x1)	68(x1) + 29(x1)	GC02
q	Steel	XF56	27003	
r	Clear Doped Linen	XF57	148	GC10

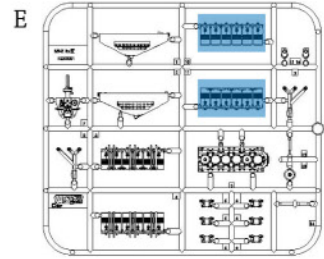
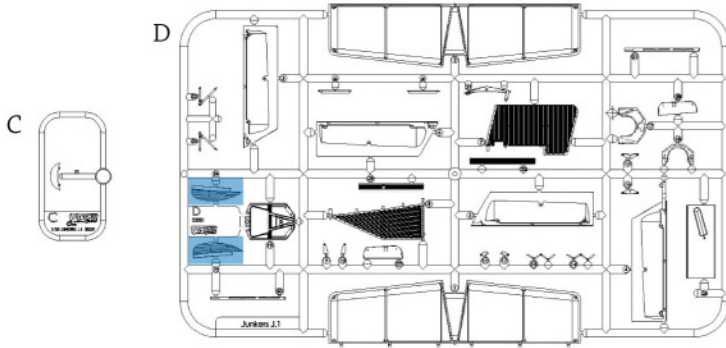
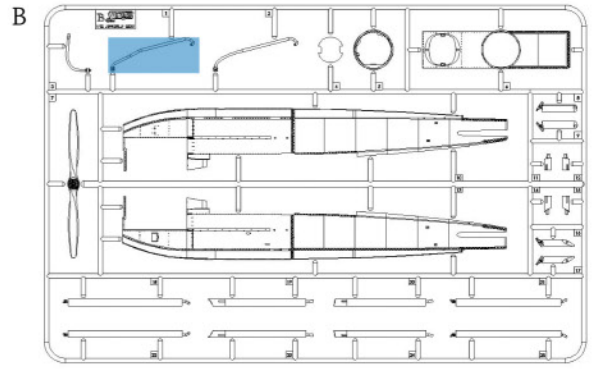
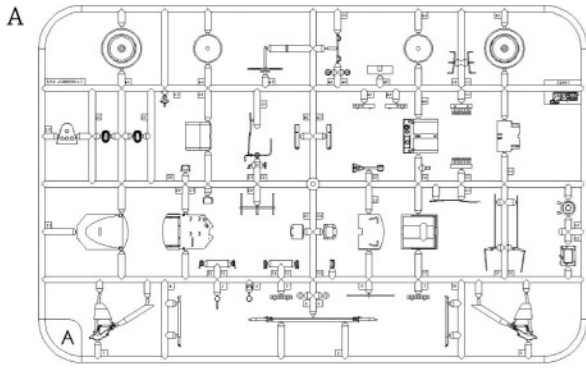

 = Not Used

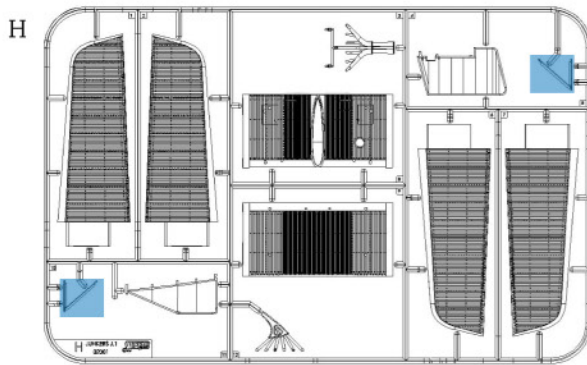
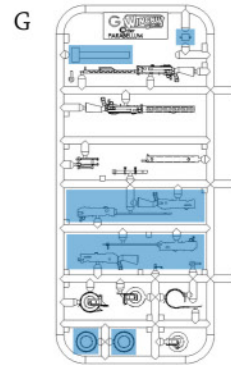
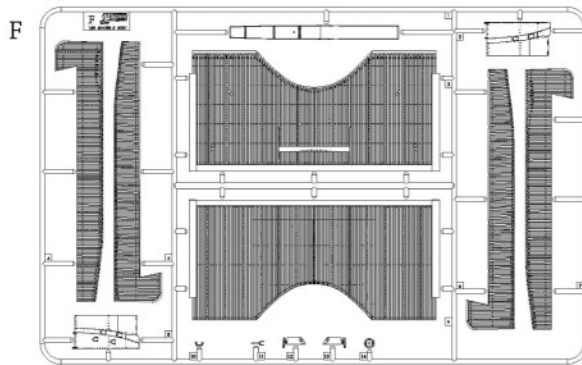

Decal Sheet

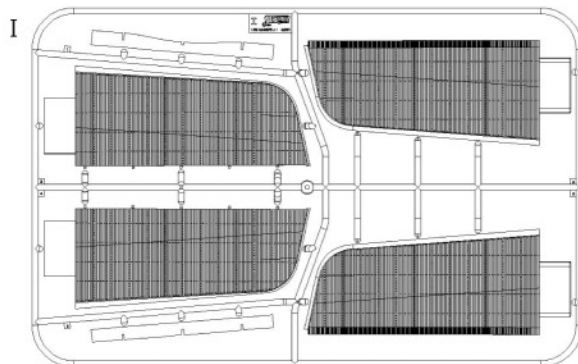
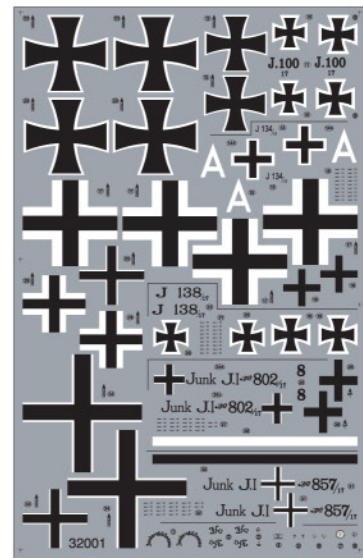
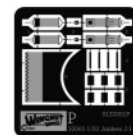
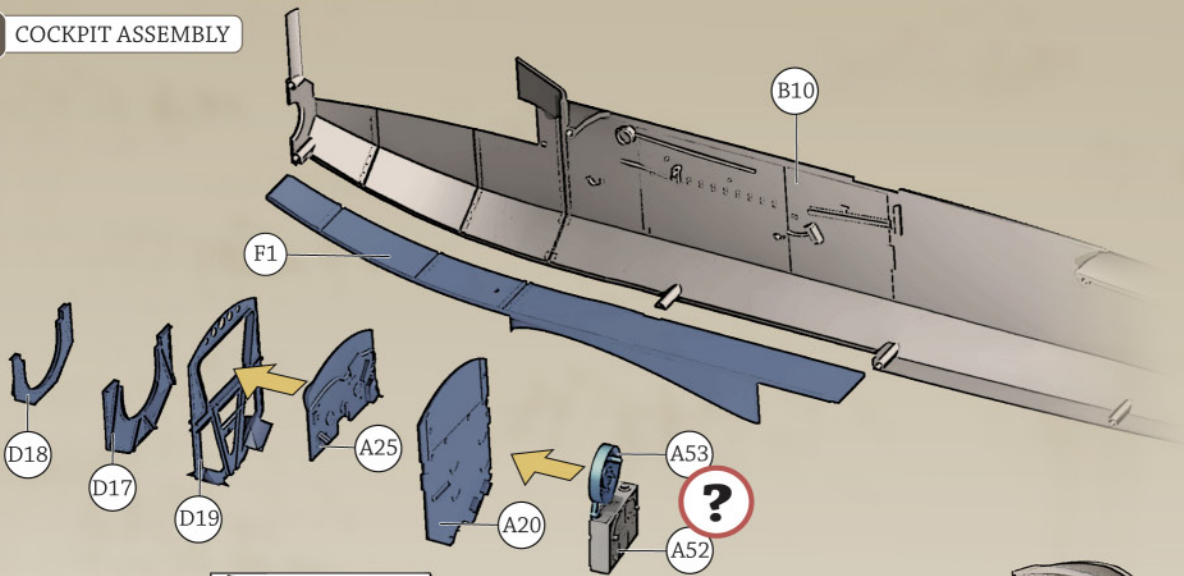

Photo Etch



1 COCKPIT ASSEMBLY



2

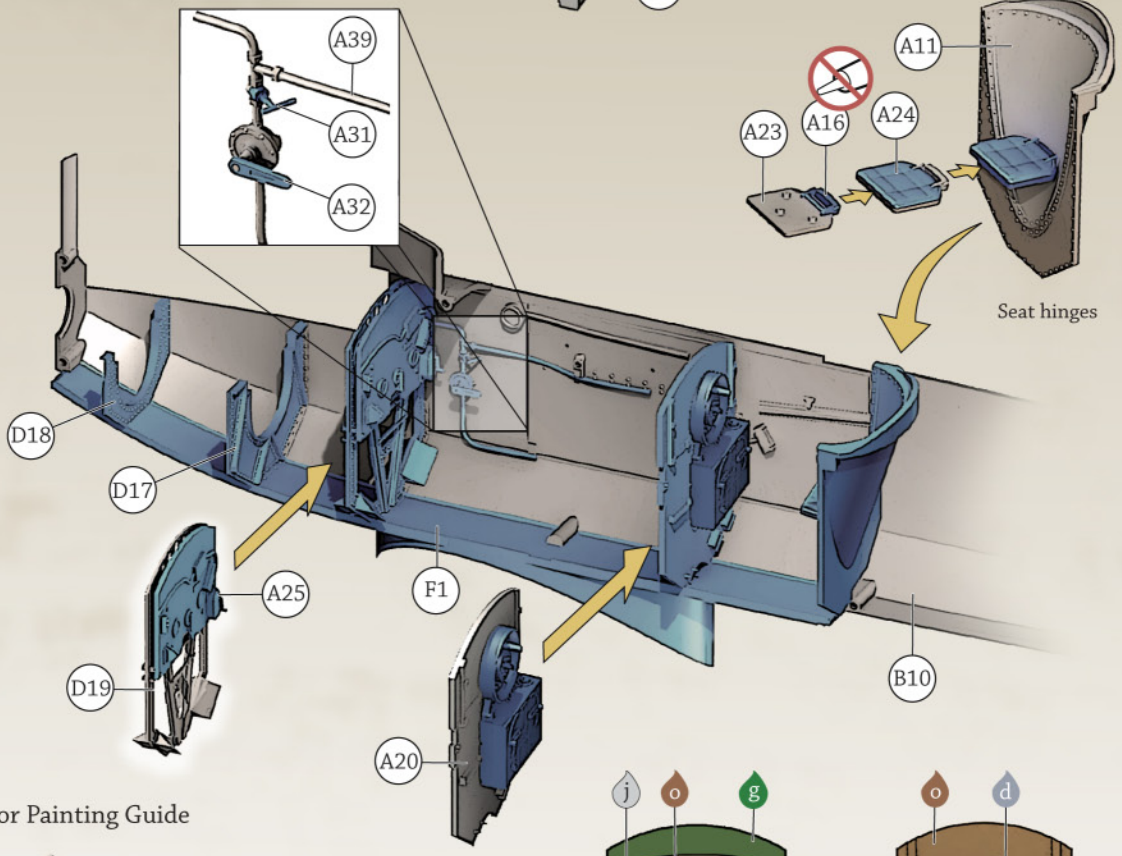

Interior Painting Guide

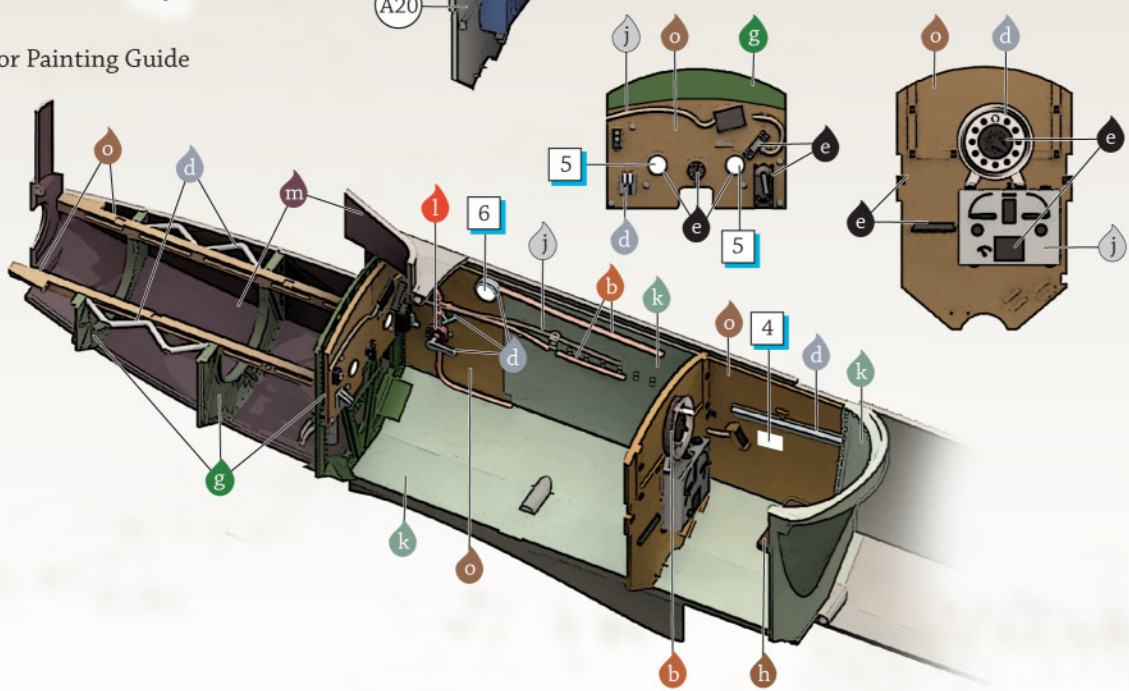

3

3

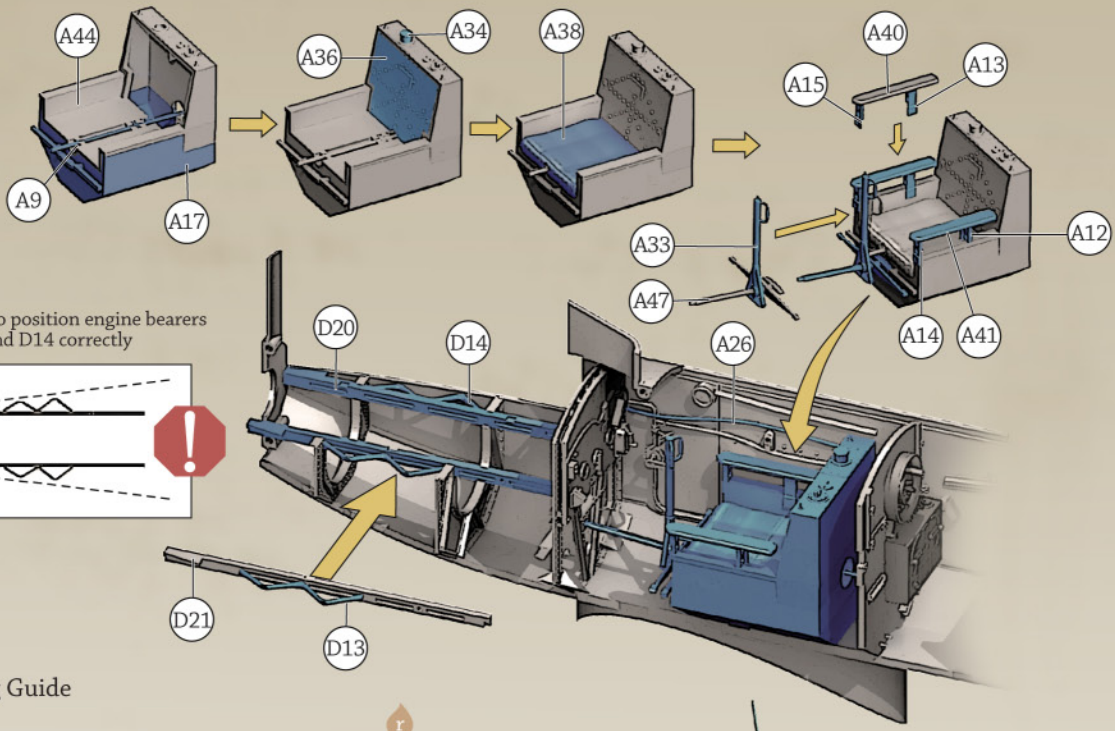

Painting Guide

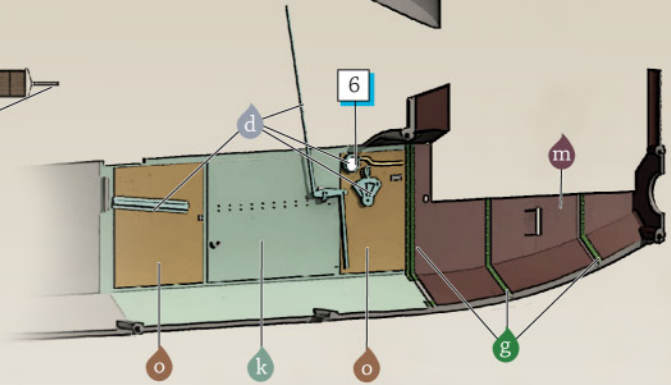
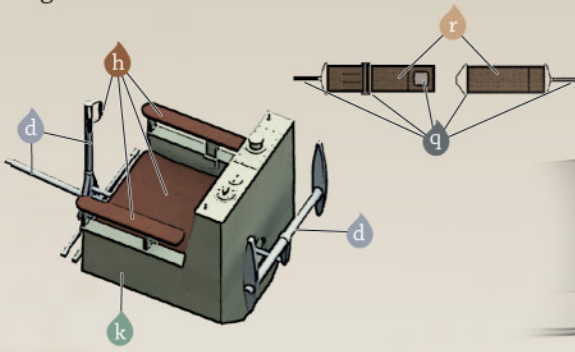

4

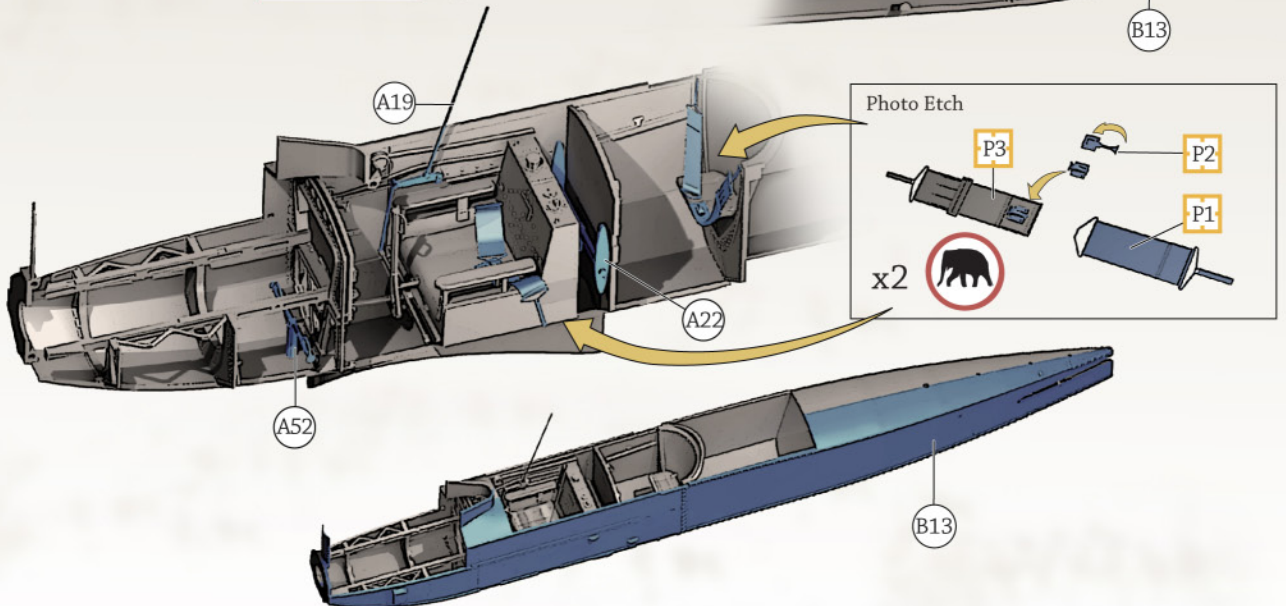
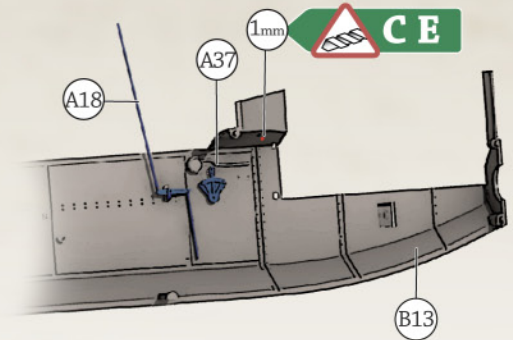
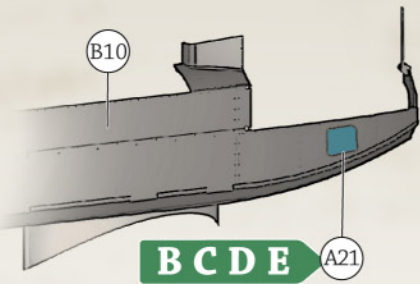

5



Holes vary between aircraft

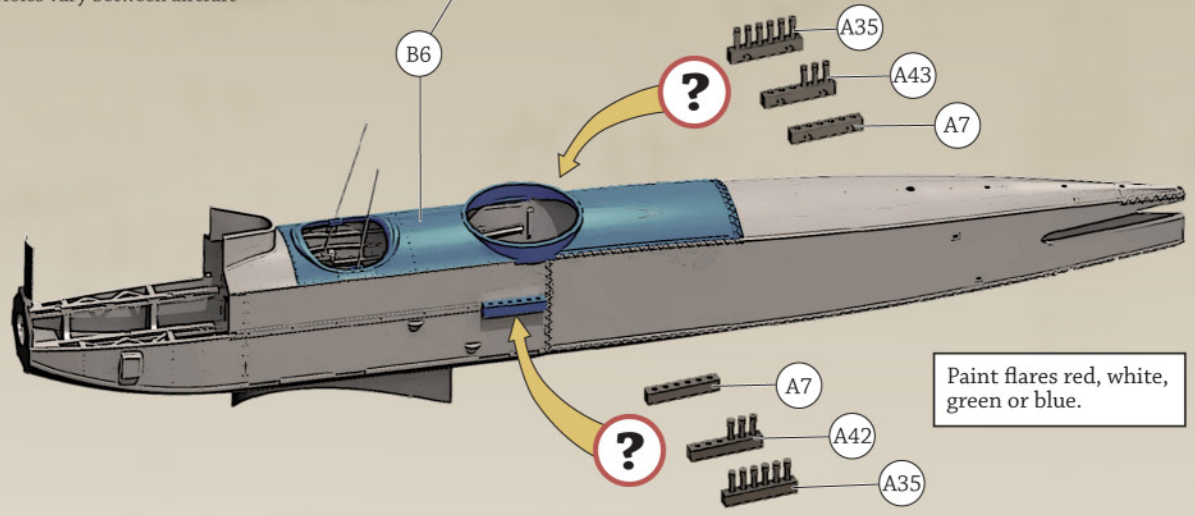

6

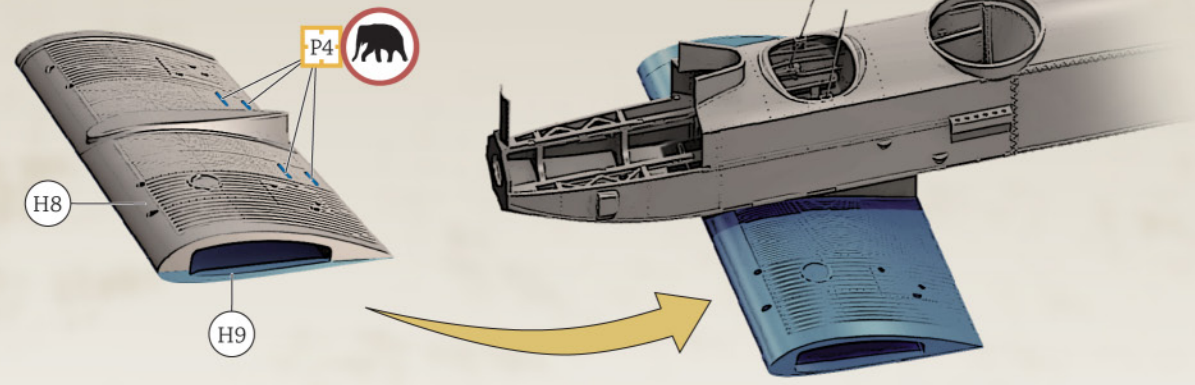

Details vary between aircraft

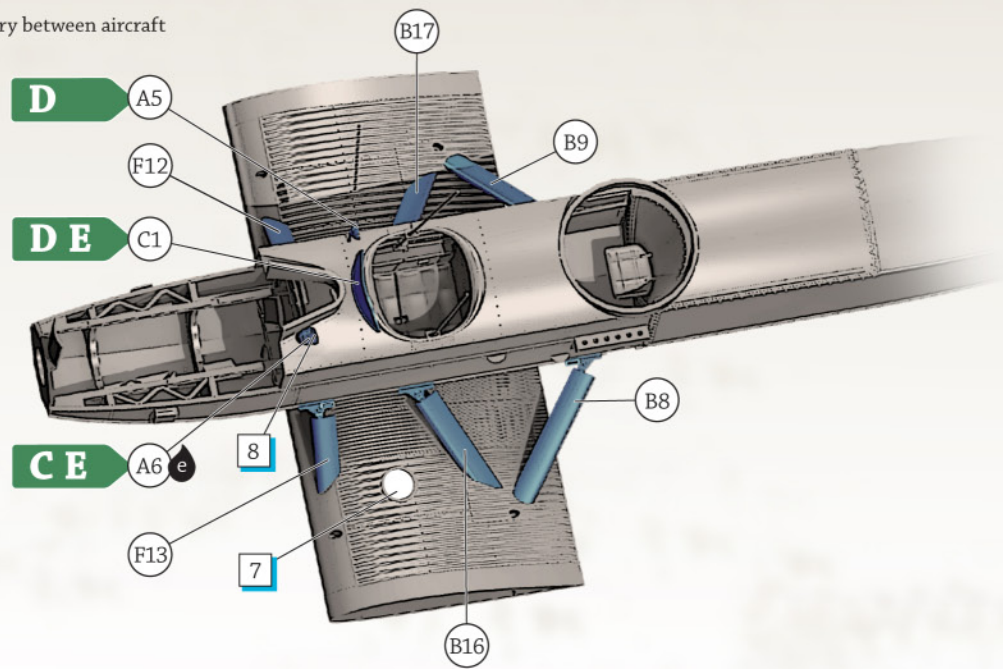

7 STABILISER

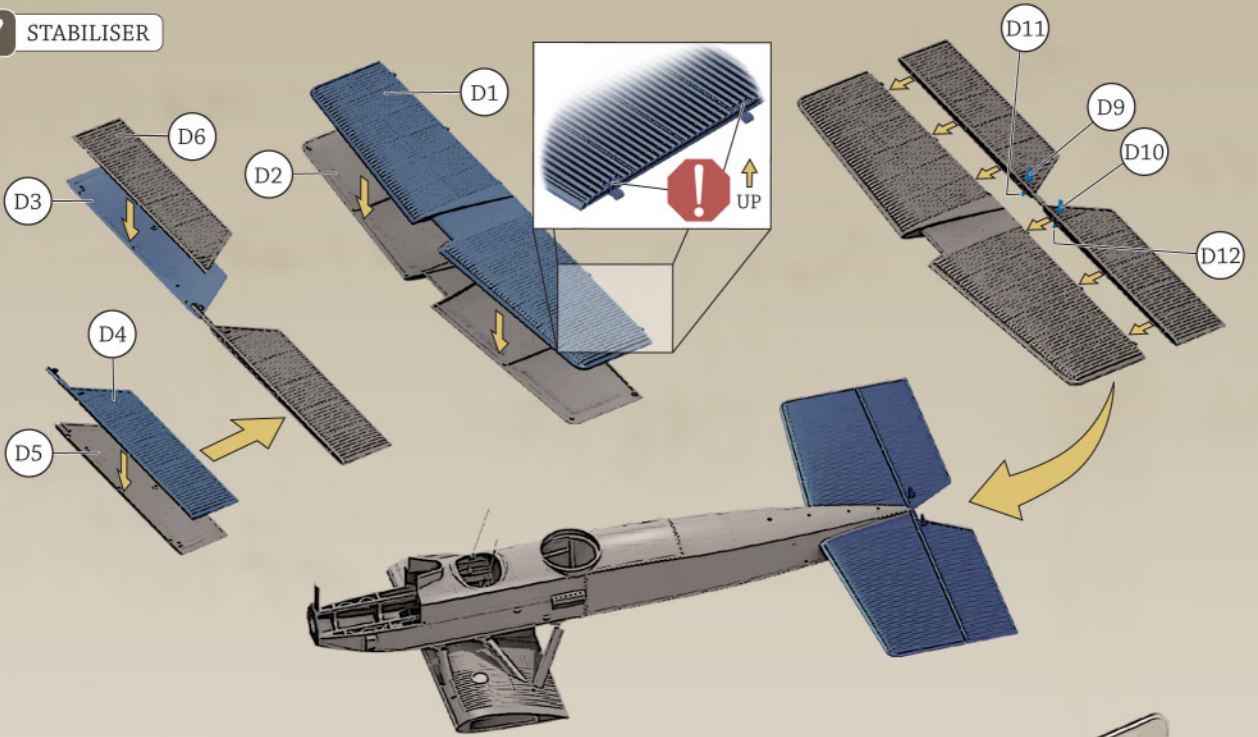

8 RUDDER

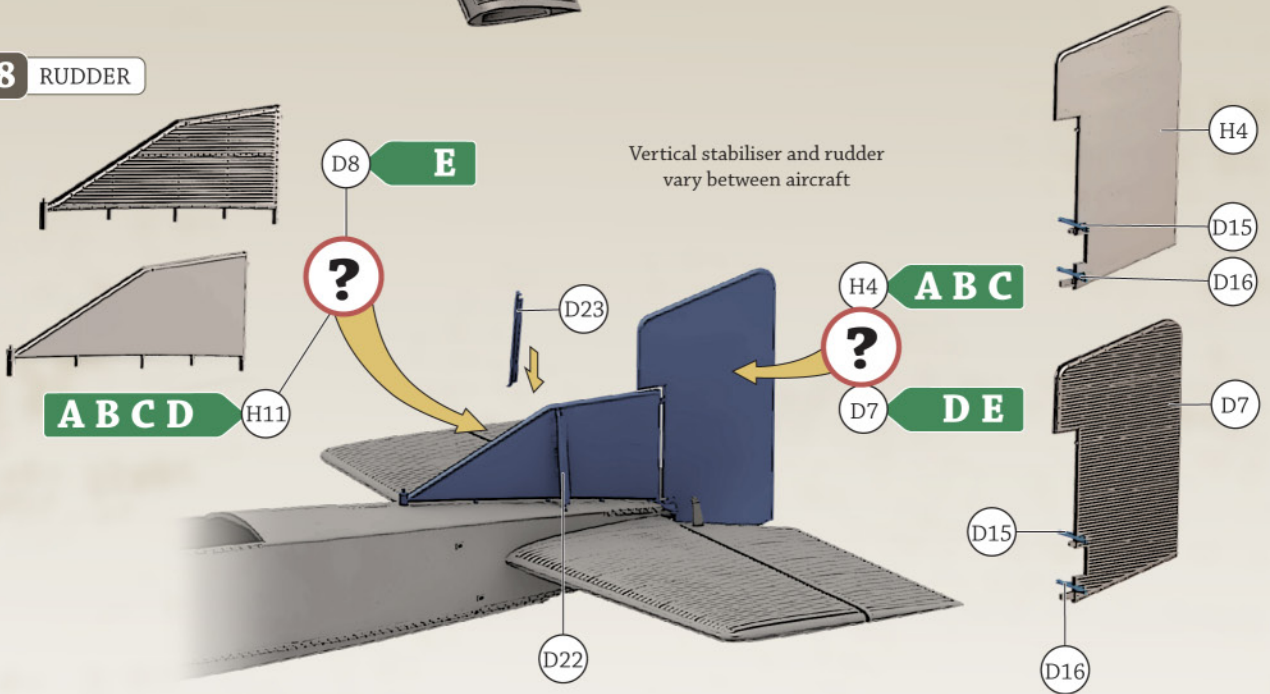

9 TAIL SKID

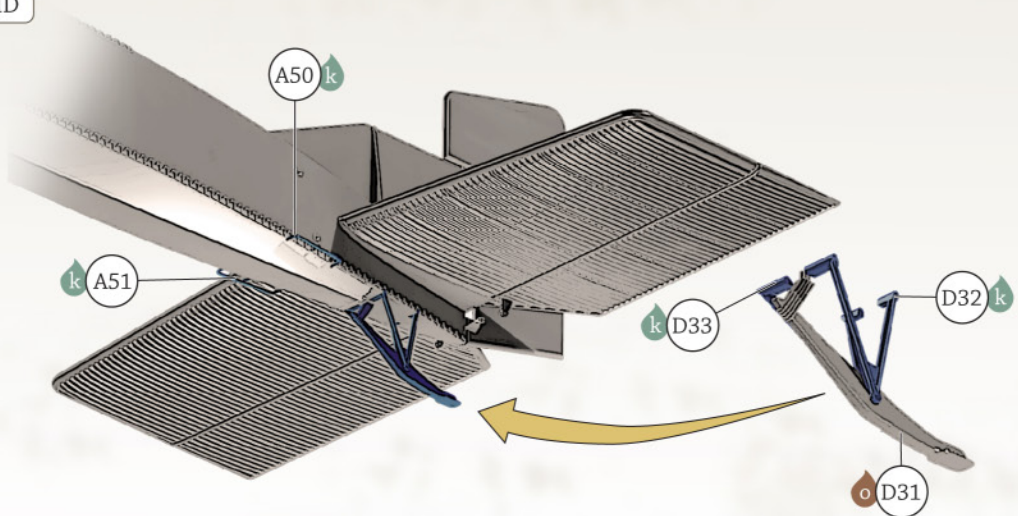

10 BENZ Bz.IV ENGINE

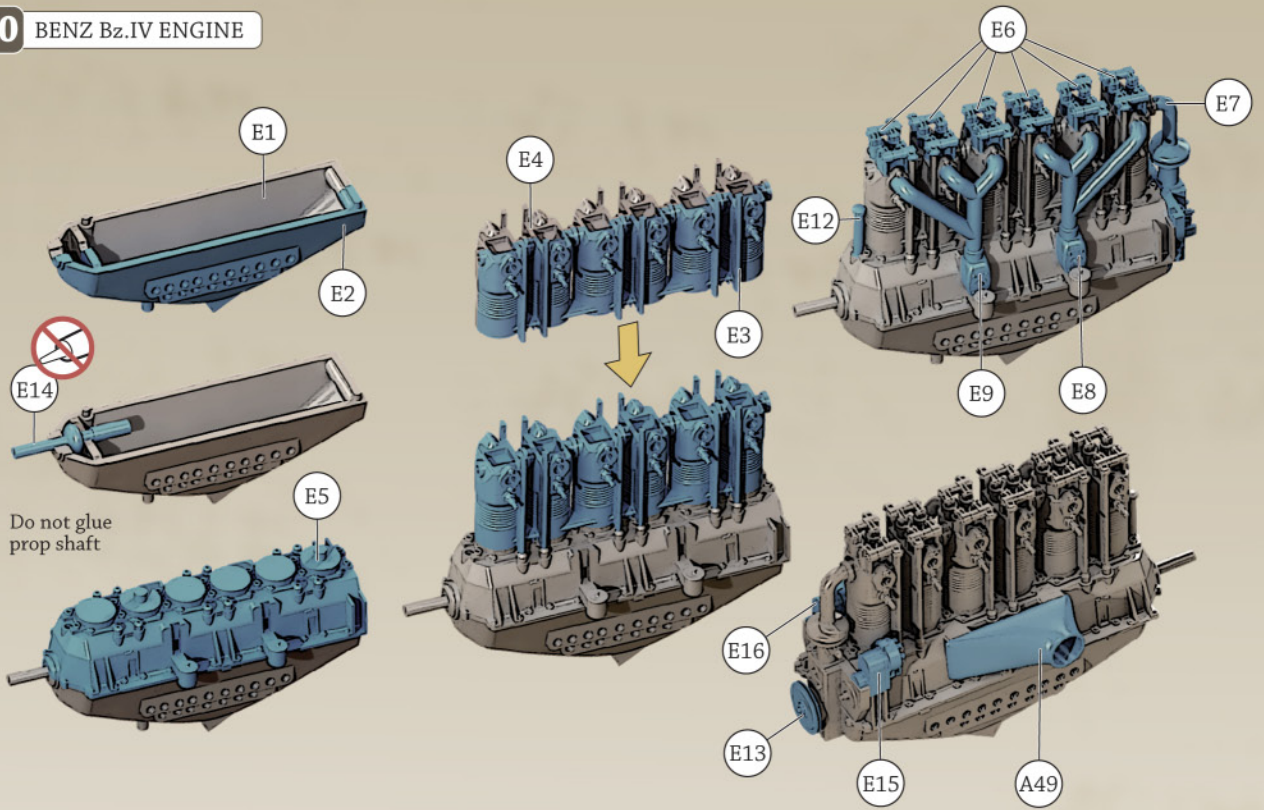

Engine Painting Guide

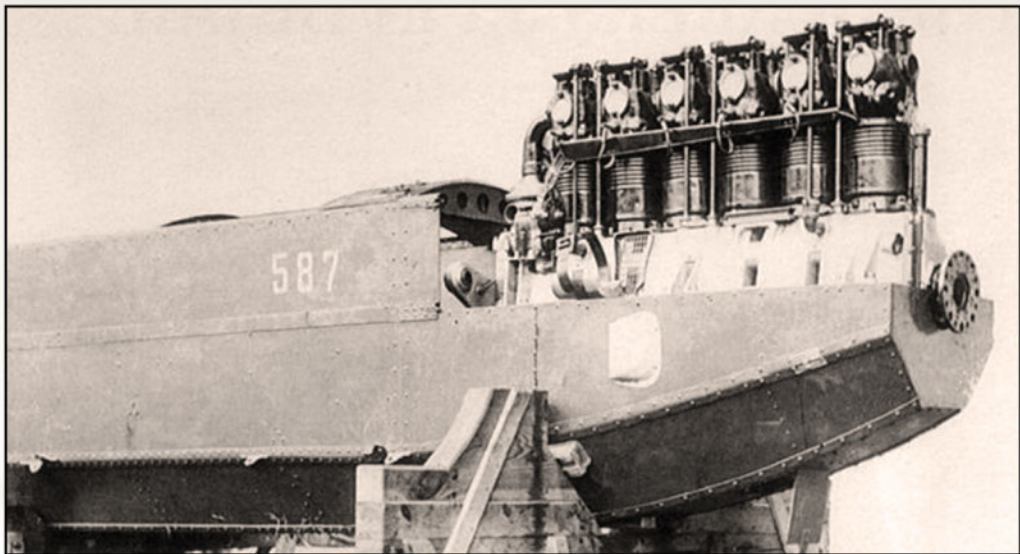
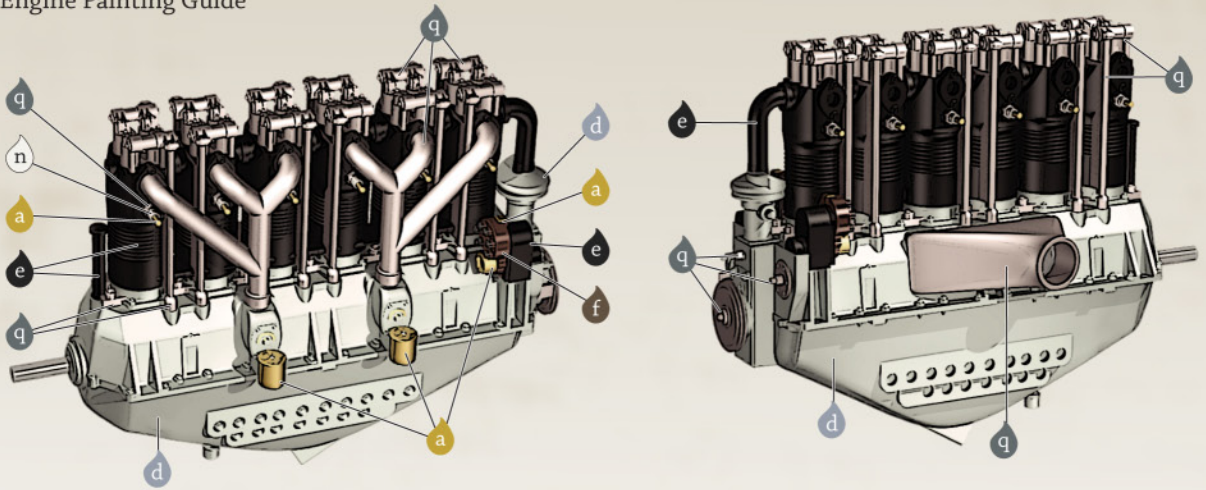

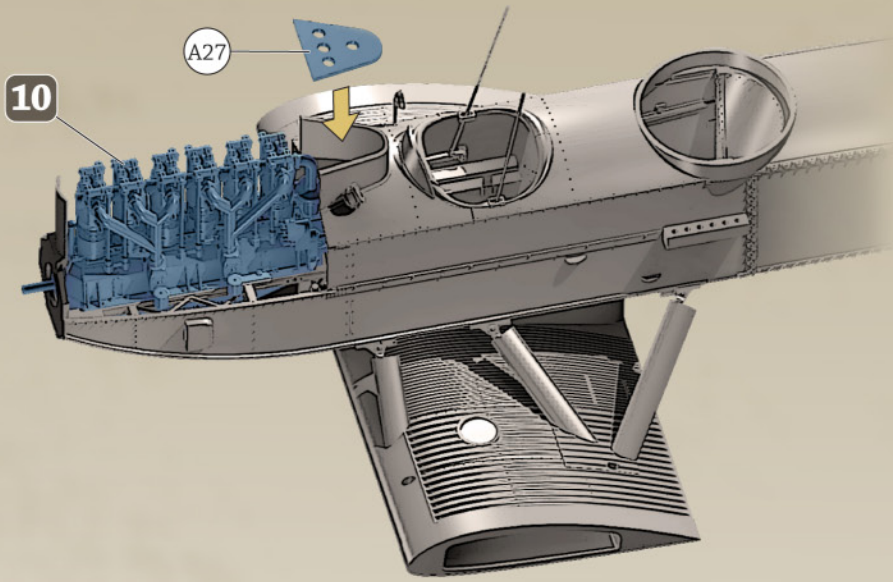

11 UPPER CENTRE SECTION



12 ATTACH UPPER CENTRE SECTION

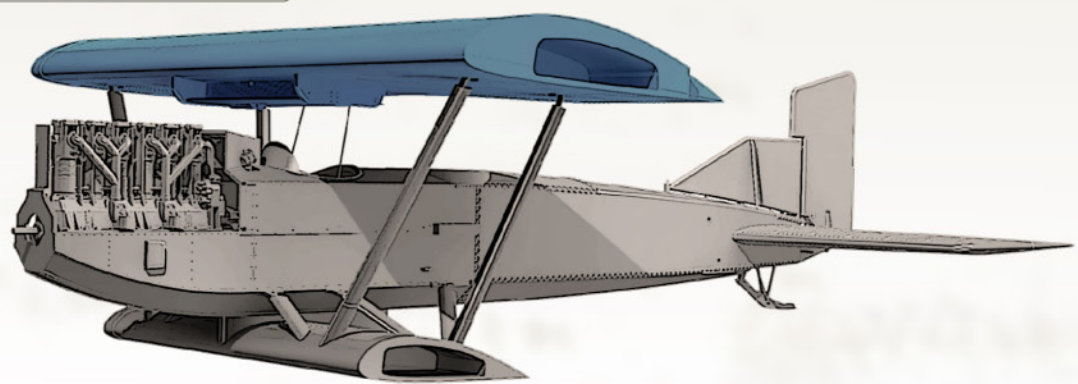

13

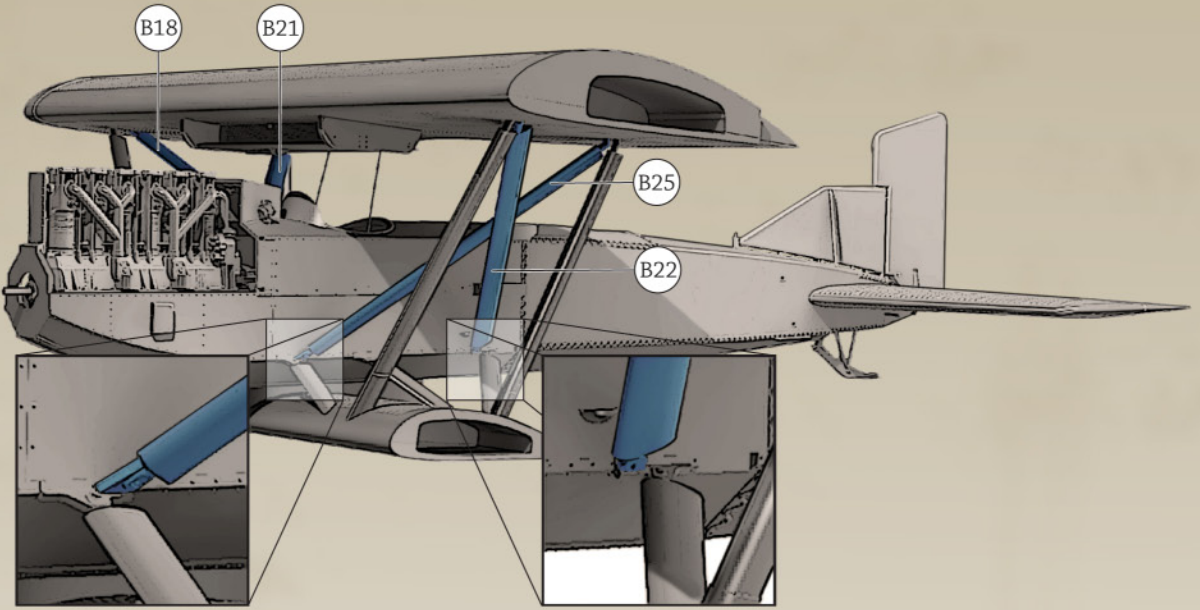

14 UNDERCARRIAGE

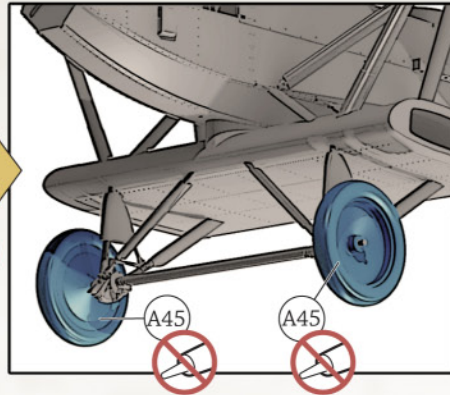
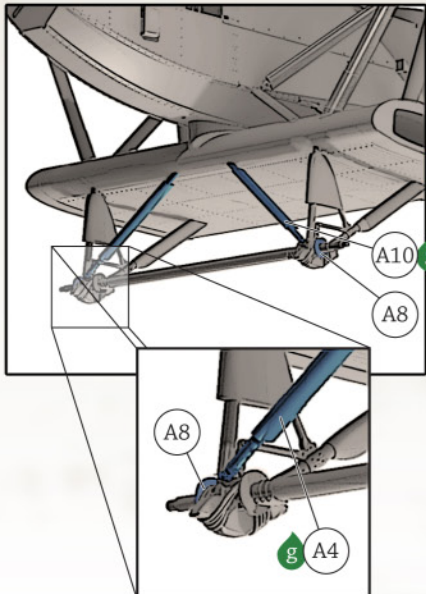
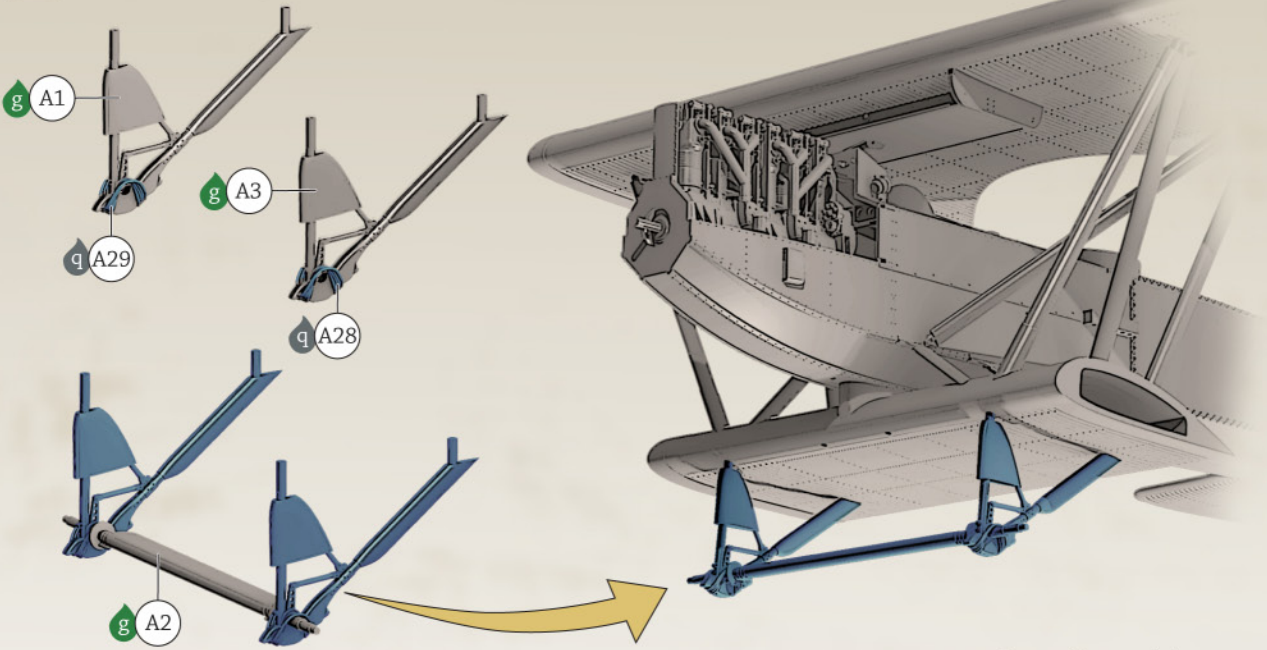

Glue washer to axle but allow wheel to rotate

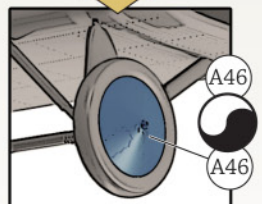
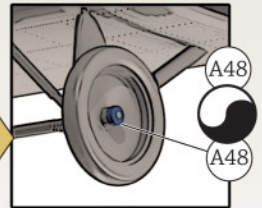

Glue wheel cover to tyre

15

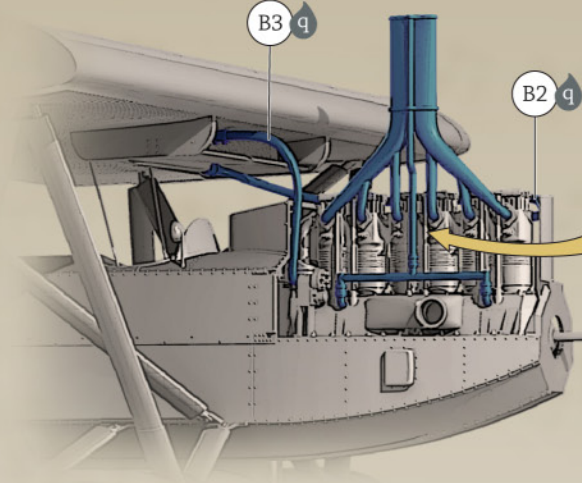

H12 **A**

?

H3 **BCDE**

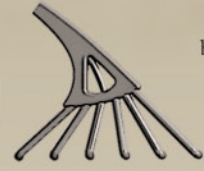

Exhaust varies between aircraft

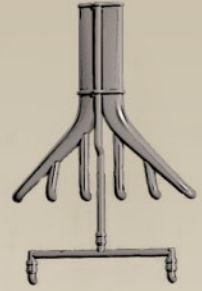

16

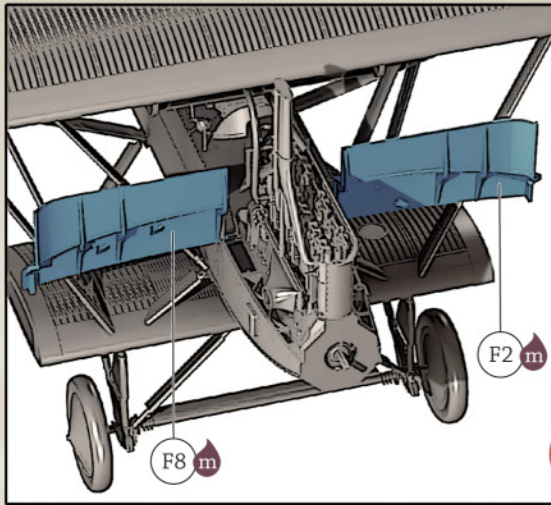

Engine covers open

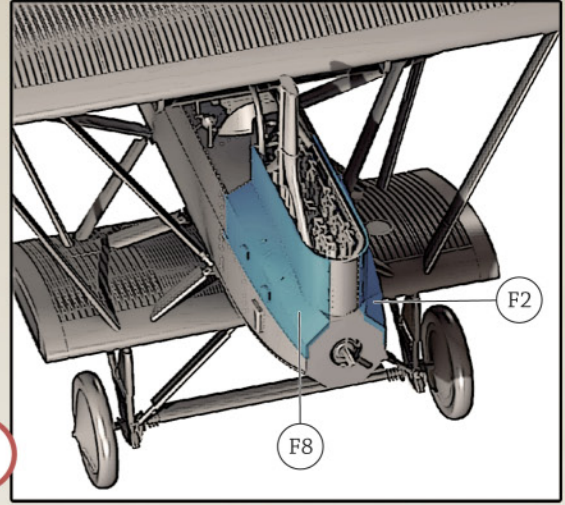

or closed

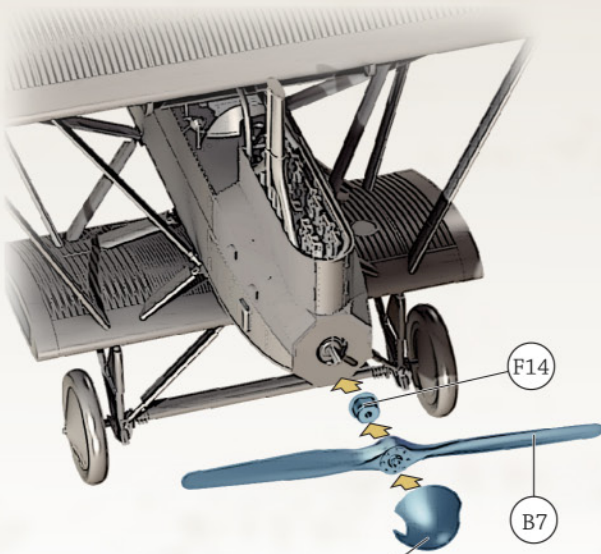

Spinner only needed for

ACD

B4



Note engine bay interior bracing of this captured Junkers J.1.

17 WINGS

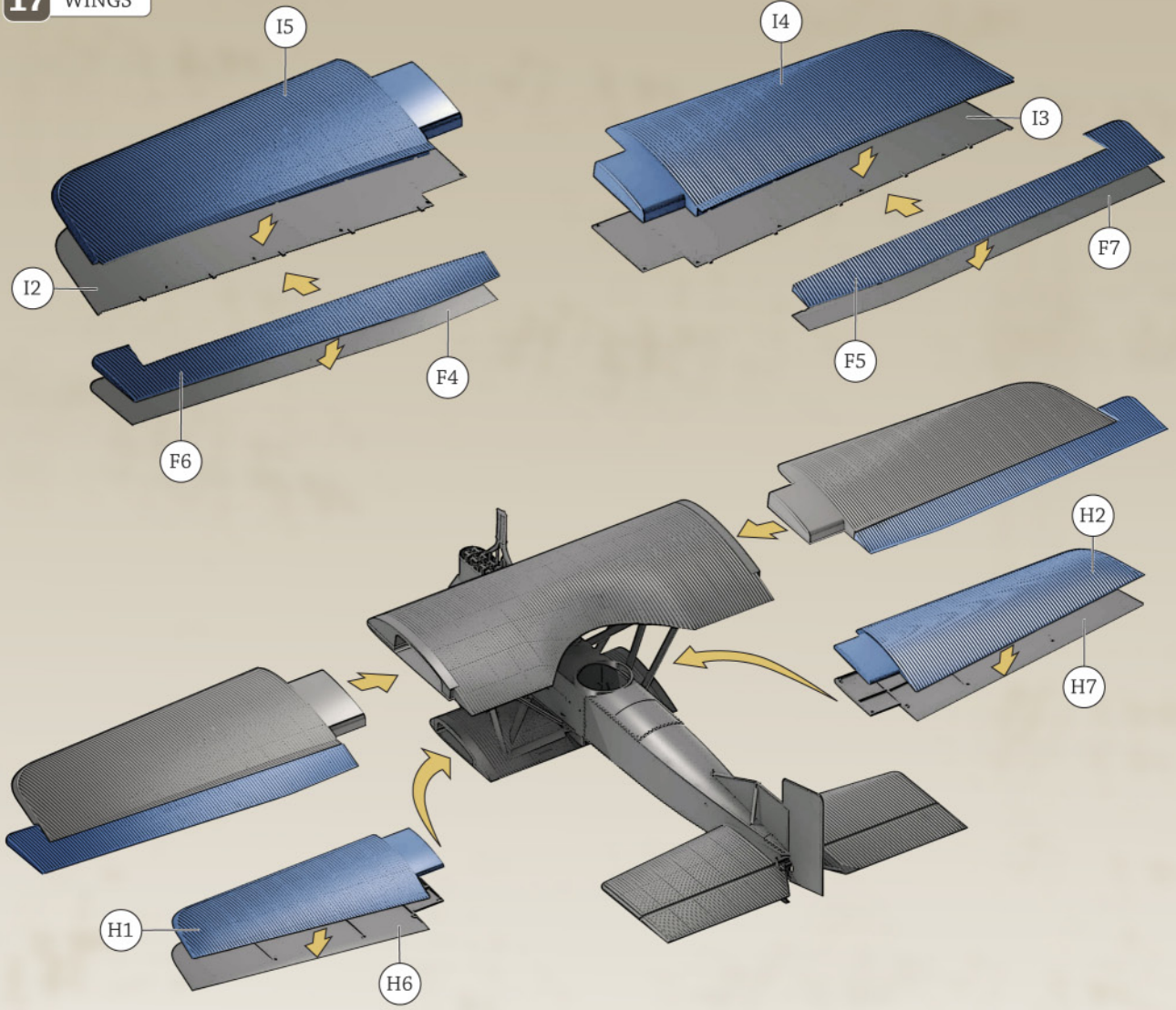

18 MACHINE GUN

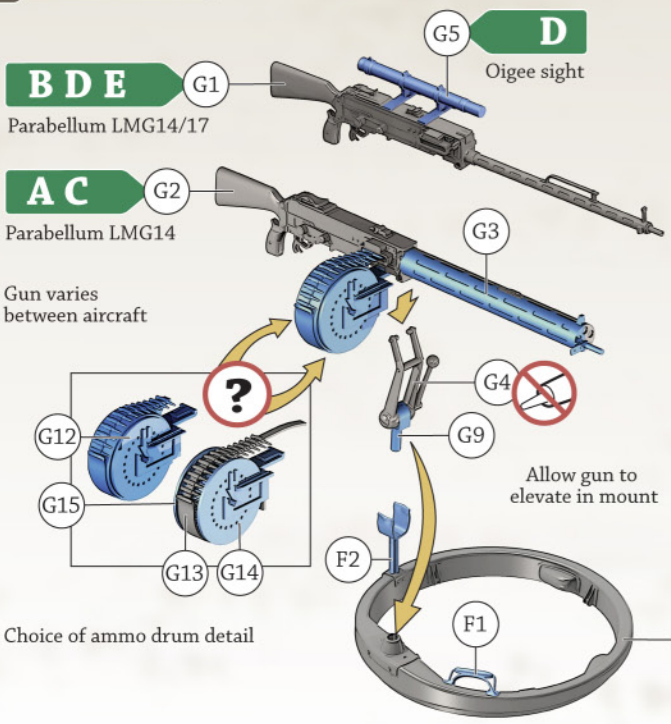

Painting Guide

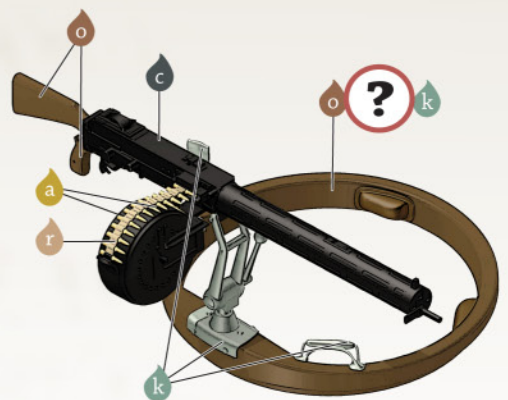

19 FINAL ASSEMBLY

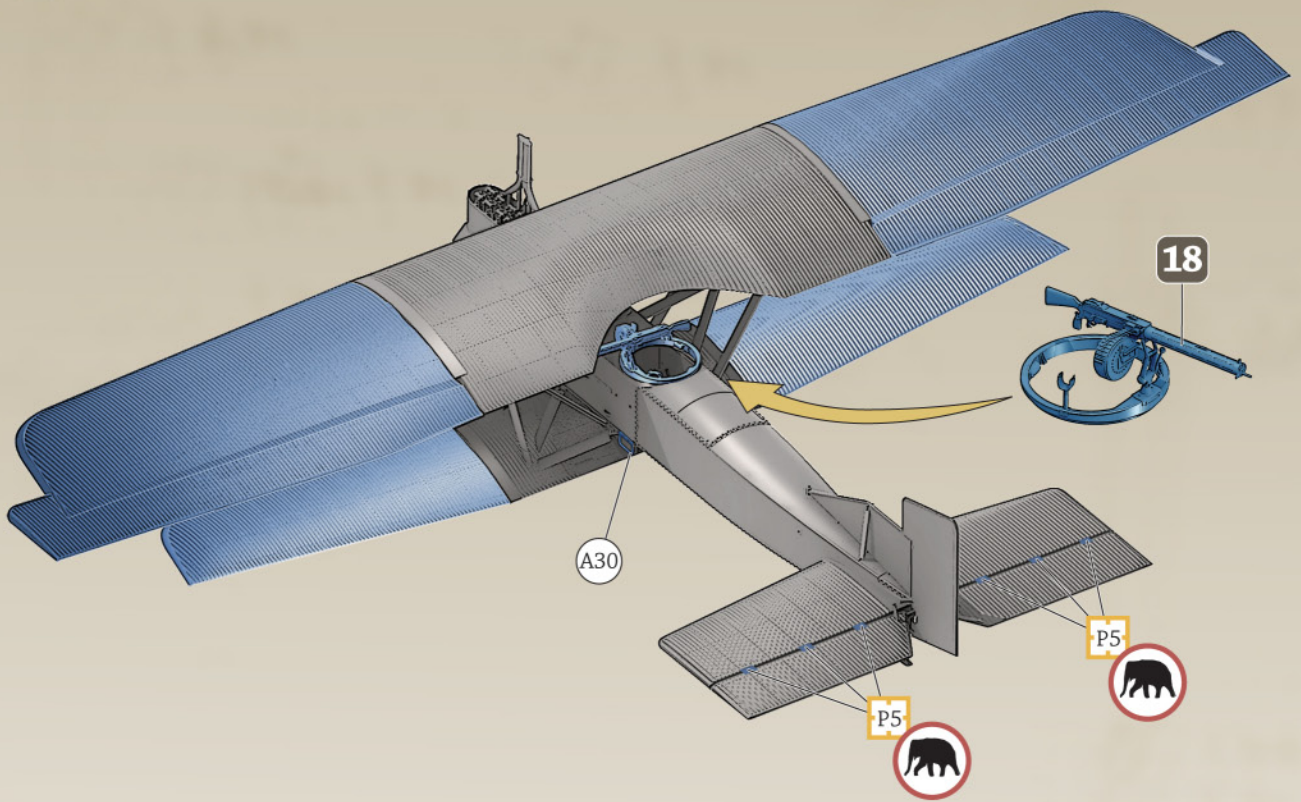

140/17 displays its camouflaged top surfaces.



Another view of 140/17 showing the Junkers J.1 thick wing profile.

A 100/17 Flieger-Abteilung 19, 1917

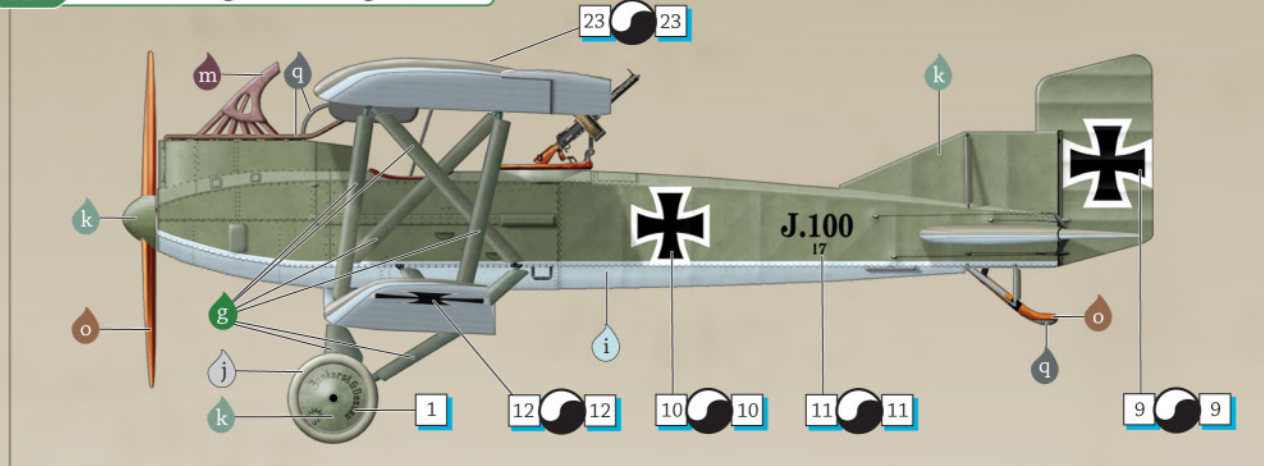

B 134/17 Flieger-Abteilung (A) 263

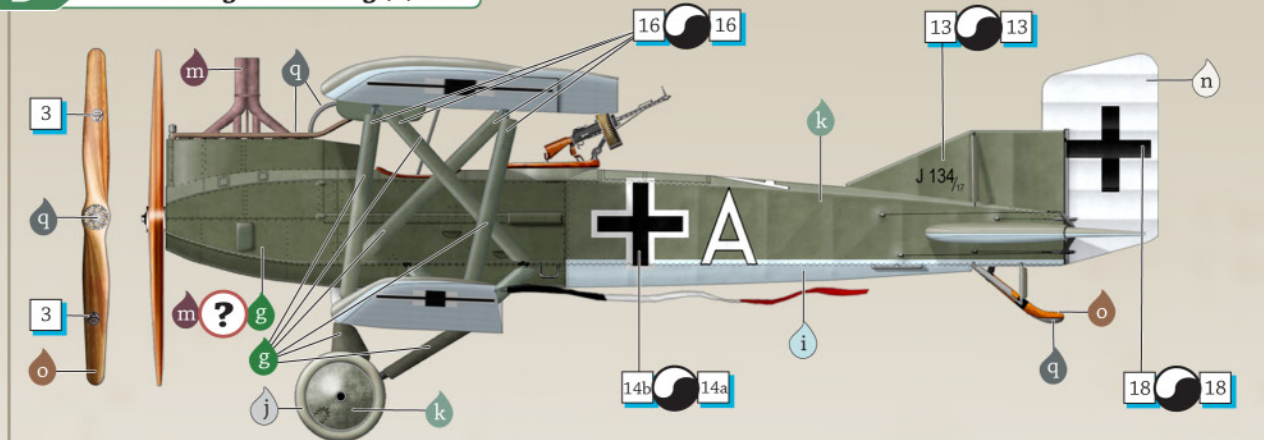

Paint upper surface the same for

ABD

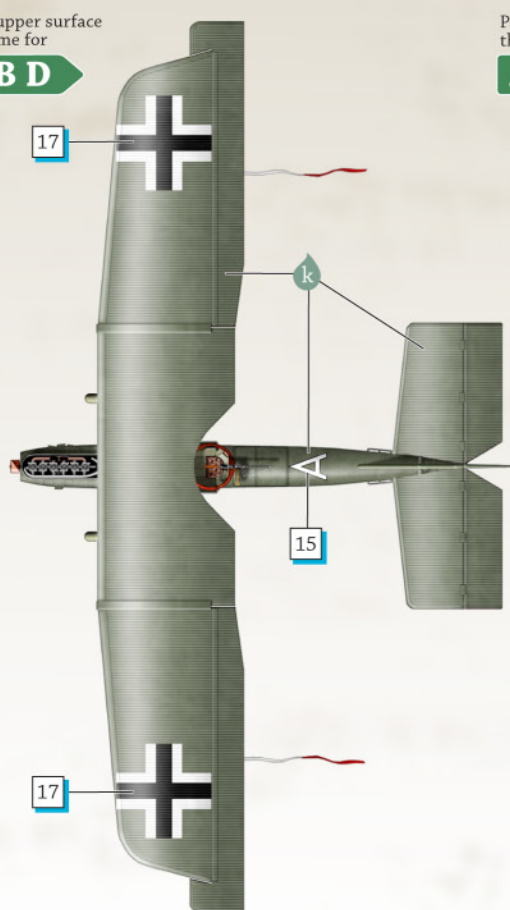

Paint lower surfaces the same for

ABCDE

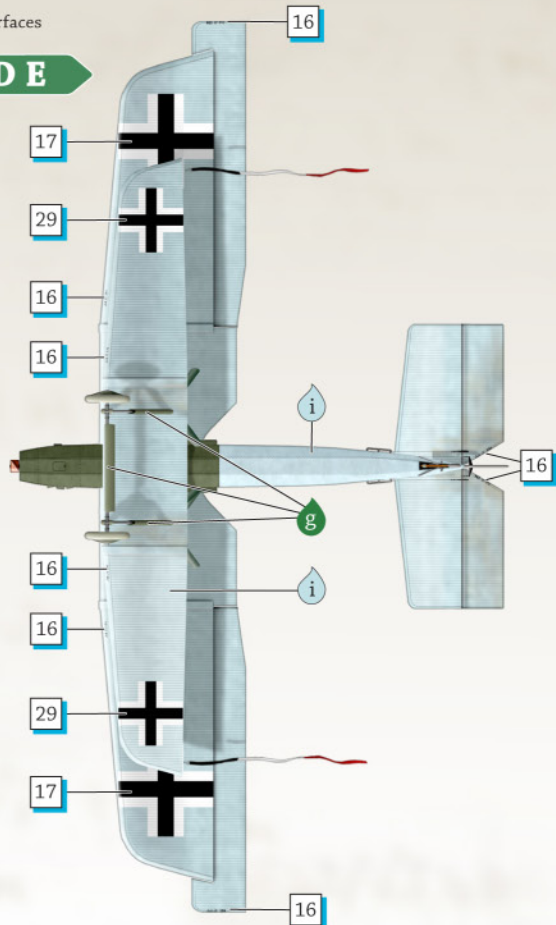

C 138/17 Flieger-Abteilung 17, 1918

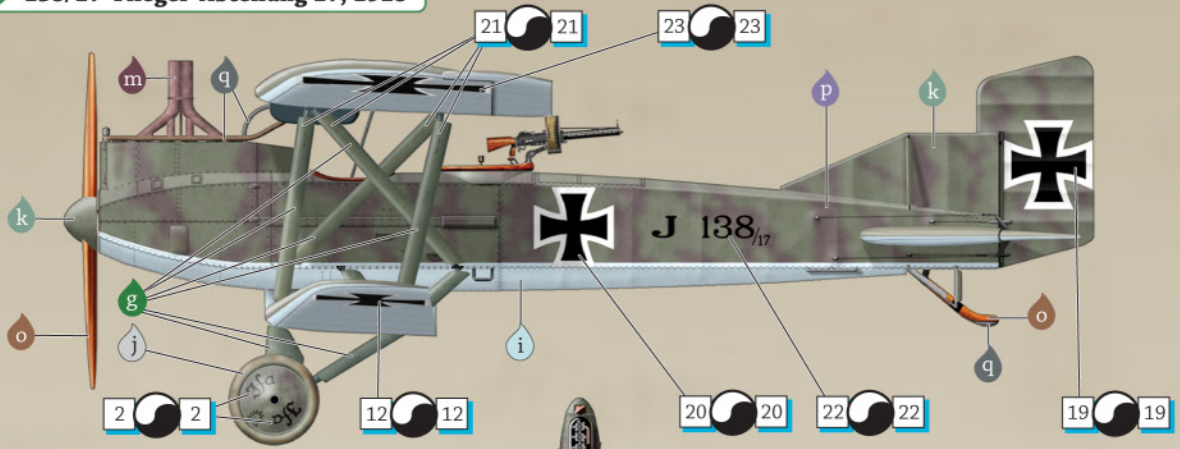

Paint upper surface
the same for

CE

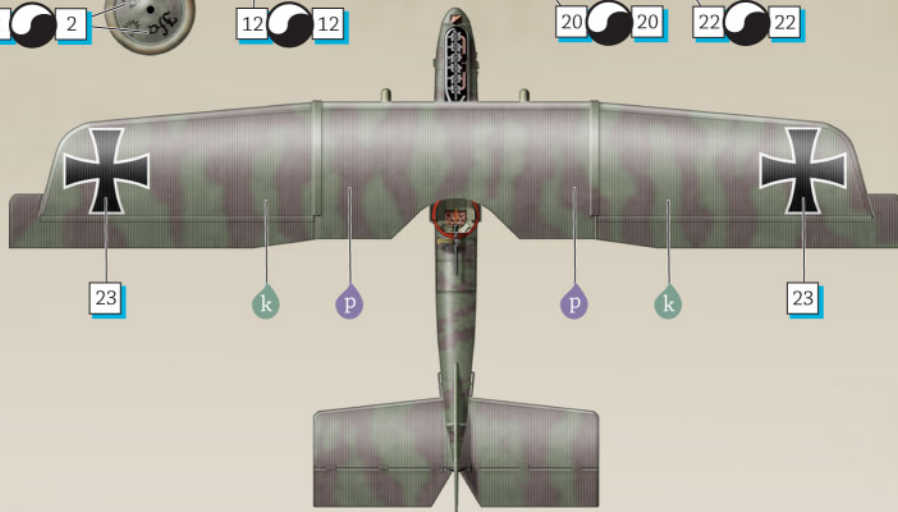

D 802/17 Unidentified Unit, 1918

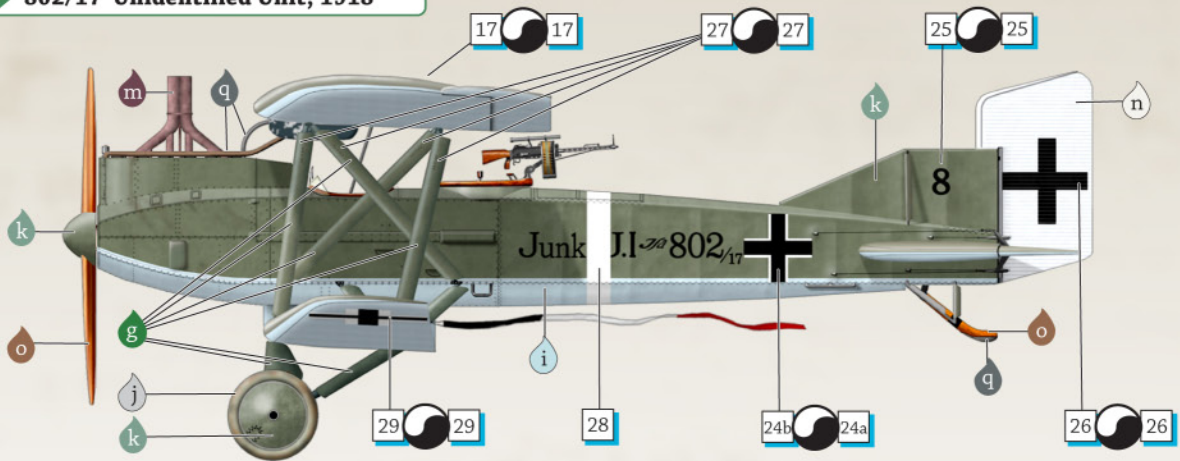

E 857/17 Flieger-Abteilung (A) 263, 1918

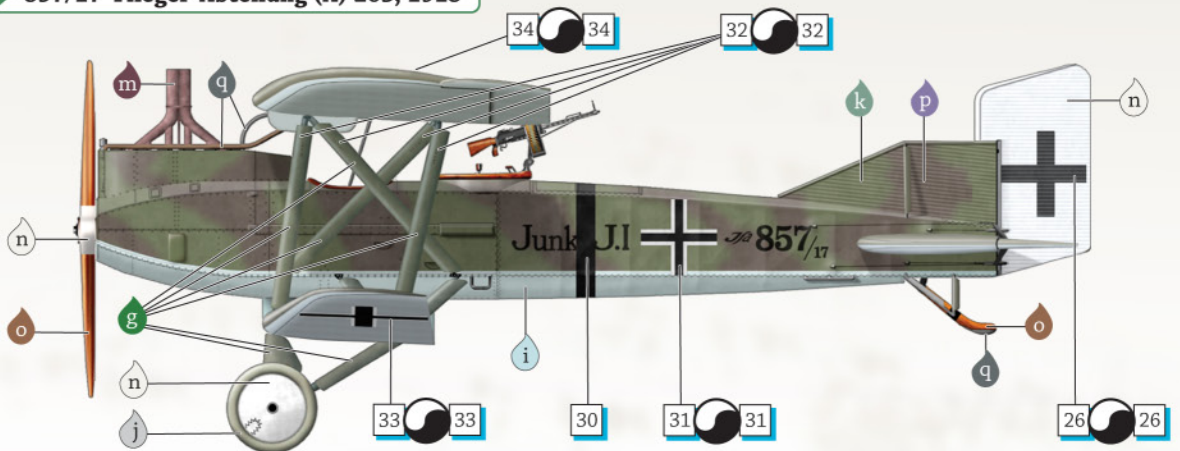

Despite being an almost bulletproof aircraft of revolutionary design only two Junkers J.1s are known to exist today. The unrestored but relatively complete 586/18 in the Canada Aviation Museum, Ottawa, Canada and a fuselage currently in the Deutches Technikmuseum, Berlin, Germany. We are indebted to both these museums for the colour photos you see here.

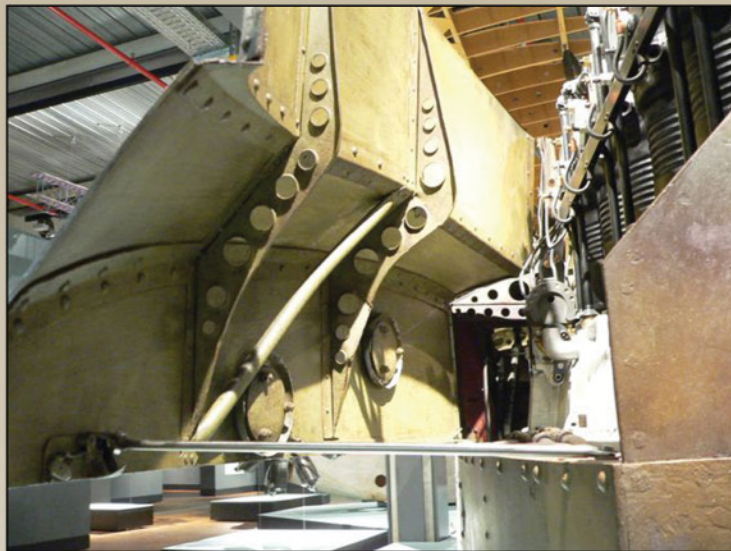

Note details inside armoured engine side cowling (Berlin).

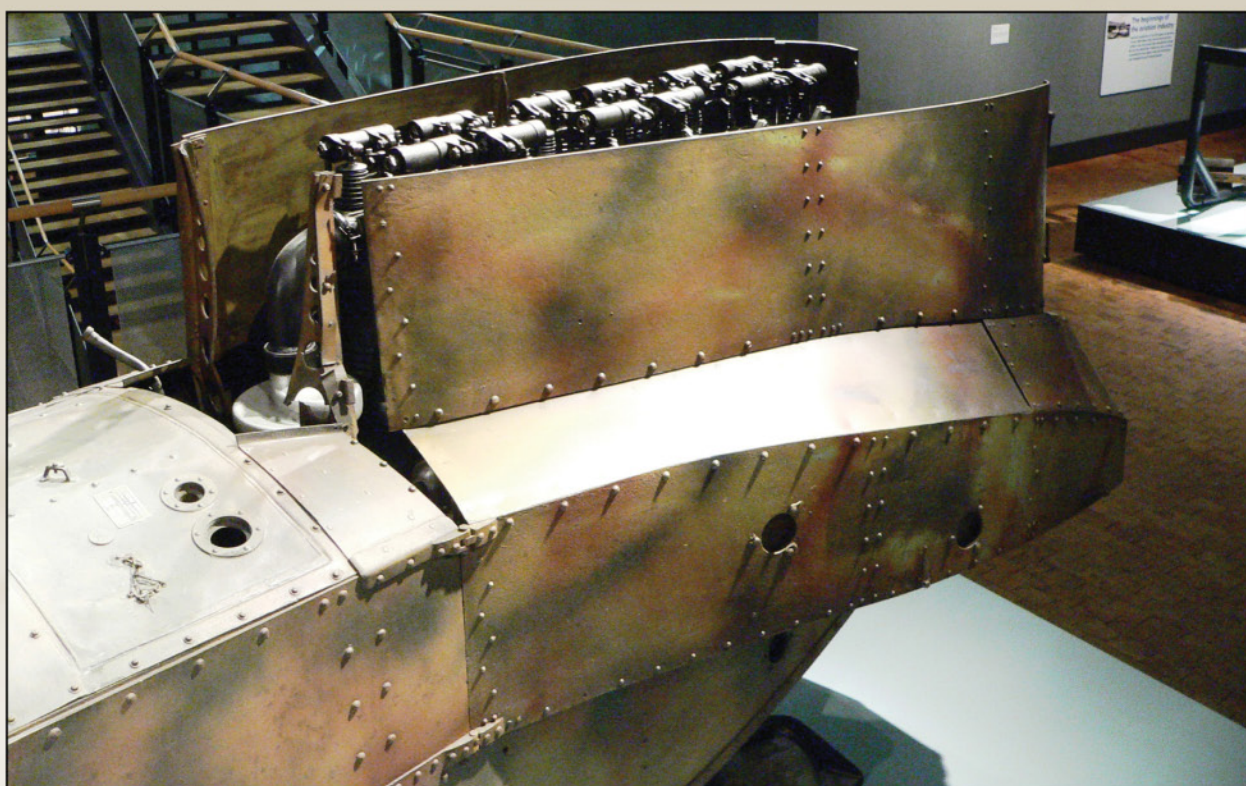

Note the prominent rivets on the armoured plate surfaces. The camouflage scheme depicted in this photo is not realistic and has subsequently been painted in more appropriate colours following a recent restoration (Berlin).



Original red oxide primer under camouflage colours (586/18 Canada).



Lower surfaces painted a sand colour to represent the clear doped linen of a less aggressive aircraft. Dark green strut fairing. (586/18 Canada).



Hole in lower left wing for compass (586/18 Canada).



Elevator and rudder control cables exiting the rear of the armoured fuselage section (586/18 Canada).

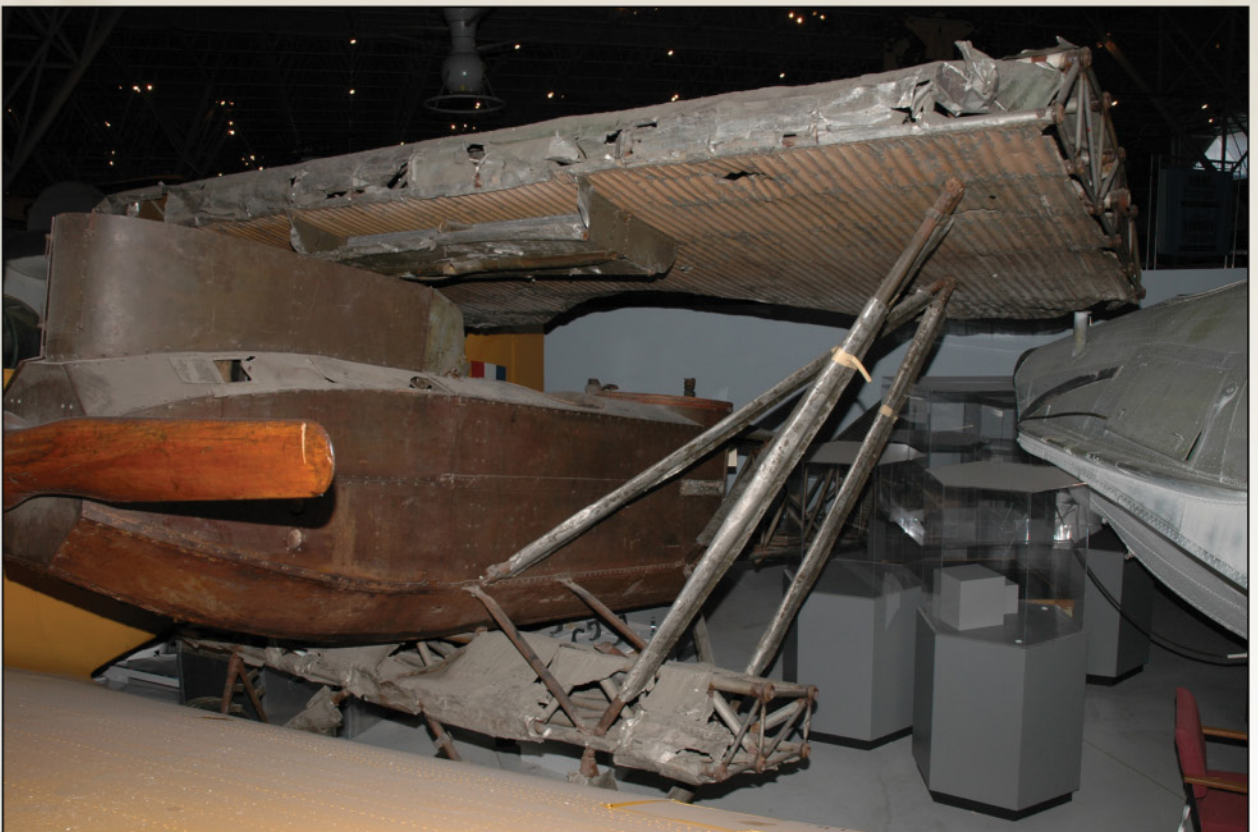

(586/18 Canada)



Rear observer/gunner cockpit. Unfortunately many fittings are missing. Note 'horseshoe' mounts on bulkhead for the radio (586/18 Canada).



Pilot's cockpit of 586/18. Note the unusual aileron crank arrangement.

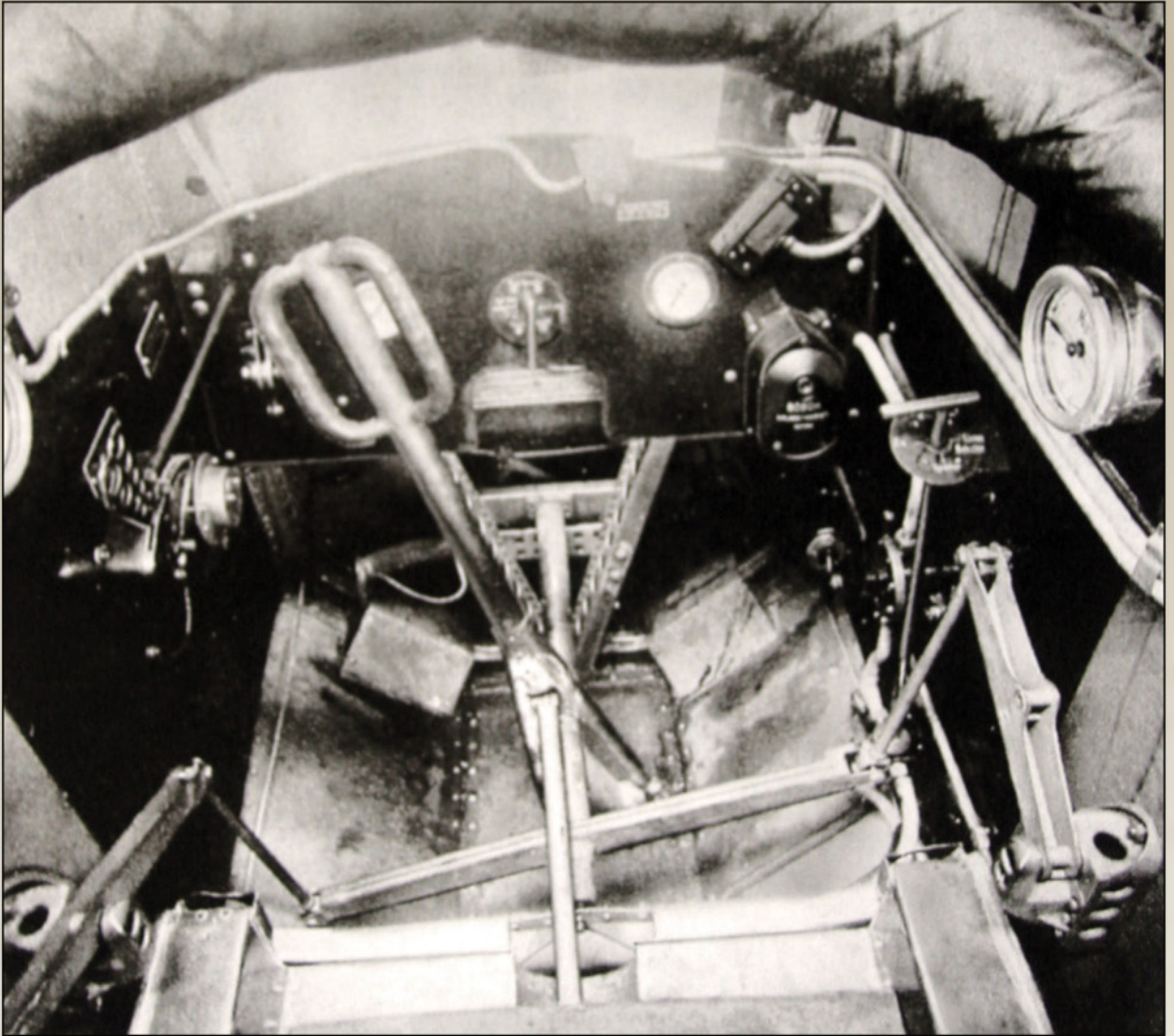

Neither of the two museum aircraft feature a complete cockpit so we are lucky to have this contemporary photo showing the instrument arrangement.



(Berlin)



The stripped fuel tank which makes up most of the pilot's seat (Berlin).



This photo opportunity following a spectacular, but not too uncommon, landing accident allows us to view the irregular mauve over green camouflage pattern.



Post war wreckage displaying it's camouflage scheme. No two aircraft appear to display the same pattern.



Note the compass and radio aerial details in this close up of 140/17.



Recovery of this heavy aircraft after the almost obligatory landing accident presented a few more problems than most aircraft of the Great War.



This photo of Junkers J.1 140/17 shows the solid lines of this revolutionary aircraft to great effect.

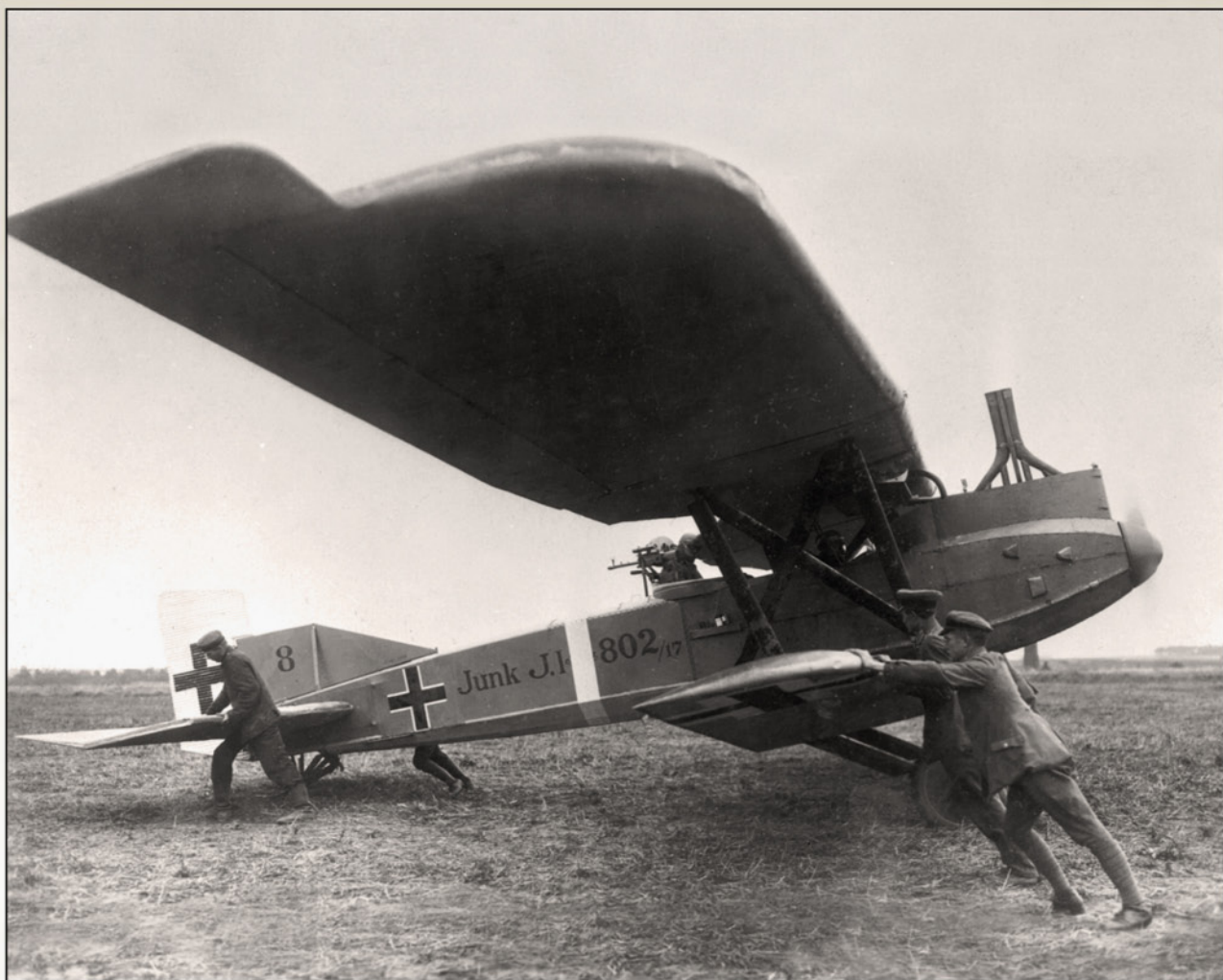

Six ground crew prevent 802/17 from taking off during this posed propaganda photograph. Other prints of this photo show wing tip streamers on the lower wings.



Note the oversized white surround to the fuselage cross on 149/17.



Two views of 836/17 which appears to have a white(?) number "1" painted on the side of the fuselage. Also note the brave teddy bear precariously positioned behind the Benz Bz.IV intake snorkel.



Note the 5 colour lozenge camouflage fabric on the rear fuselage of 586/18. This aircraft is now located in the Canada Aviation Museum.

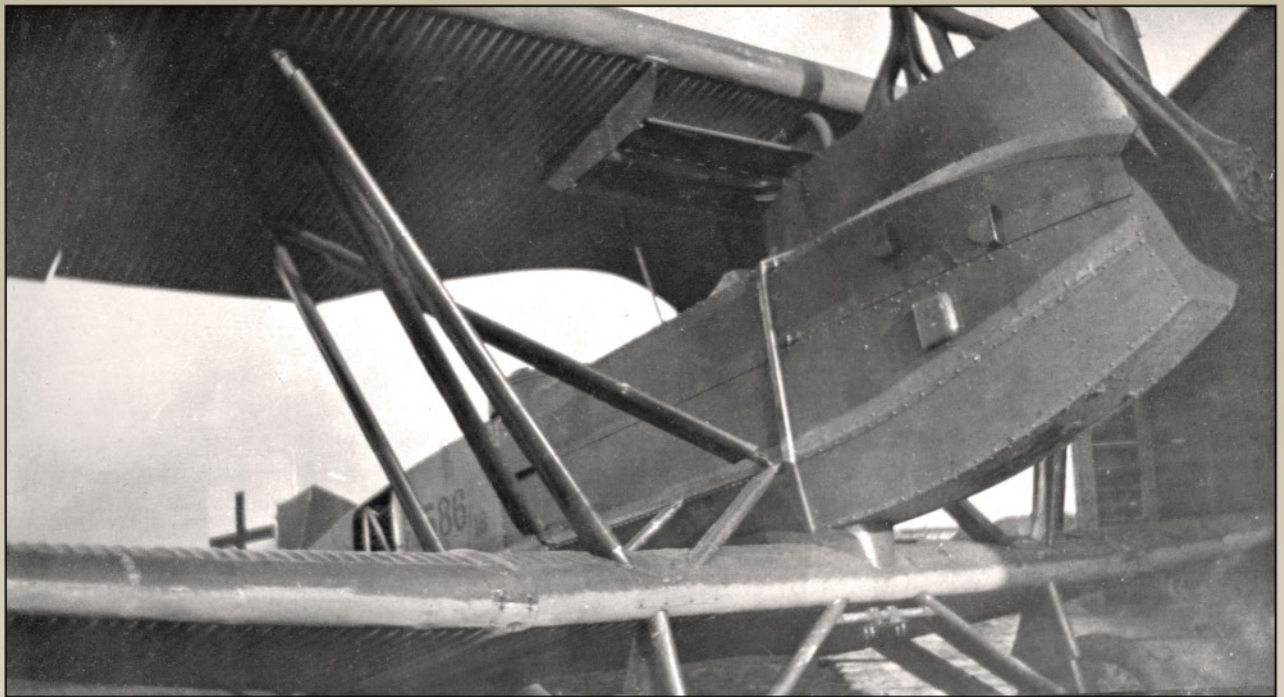

586/18 after the end of hostilities. Note the rack mounted between the center undercarriage struts and associated cable housing running down from the cockpit. Although photographic evidence of the Junkers being used as a bomber has yet to be seen, this rack could conceivably be used for bombs, or some other load to be dropped from the aircraft. The undersides of the wing and fuselage have been painted a sand colour to disguise them as clear doped linen.



3-D Modelling by Matt Fitzgerald

As a qualified Mechanical Engineer Matt's many projects have seen him travel the world working on projects as varied as race cars in the UK, designing off roaders and golf carts in the US to advanced vehicle transmissions back home in Wellington. A keen racer in his youth, Matt started with Go-Karts achieving notable success before graduating to Formula 3 Race cars in later years.

Matt worked at Weta Digital for three years where he was able to continue his passion for challenging technologies and creative projects. For recreation Matt cycles and is an avid follower of many sports.



Box Art by Steve Anderson

Steve Anderson is an avid historian of military aviation, with a special interest in the many beautiful biplanes and triplanes of World War I. The aircraft and battles of famous World War I aces such as Baron Manfred von Richthofen (better known as the "Red Baron"), James McCudden, Raoul Lufbery, Ernst Udet, Werner Voss, and other pioneers of dogfighting are among Steve's favorite subjects.

An Artist Fellow of the American Society of Aviation Artists, Steve creates works that reflect scrupulous attention to historically accurate detail, from the colorful markings on the fuselages to the time of day of an actual battle.

Visit Steve's website at: www.anderson-art.com.



Profile Art by Ronny Bar

Ronny Bar developed a keen interest in airplanes from an early age, living close at the El Palomar Air Force Base in Buenos Aires. He first flew in the back seat of a T-34 Mentor trainer at the age of ten, and was soon drawing airplanes and building models: Spitfires and Messerschmitt first... Camels and Fokkers later.

He became a successful bass player with a career lasting over 35 years in several Rock bands, recording ten albums (one of them being a National hit selling more than 100,000 copies) and performing countless concerts, TV shows and tours all over Argentina.

Now retired from the R'n'R scene, his interest returned to his early passion: Aviation Artwork. Visiting the WW1 aircraft collection at Hendon focused his already growing interest for that historic period. His artwork is regularly appearing in journals and publications like Windsock Worldwide, Windsock Datafiles, Cross & Cockade and Over the Front.

You can contact Ronny at: ronibares@yahoo.com.ar
See artwork at: www.wwi-models.org/Images/Bar/Art/index.html



Project Co-ordinator, Richard Alexander

A native of Wellington New Zealand, Richard Alexander has a long term interest in military history, race cars & local drivers from motor sports golden era of the '60's. Other interests include mountain biking, scotch and cigars.

An accomplished modeller Richard's models have twice been awarded Best Overall in Show at IPMS(NZ) National Conventions and earned him the inaugural TamiyaCon(NZ) Master Modeller award (along with the associated trip to Japan) in 2001. Many of his works are in private collections around the world, though he no longer accepts commissions.

Richard has been in the model and hobby industry since 1991 and brings with him a keen eye for detail and a passion for ensuring our models are enjoyable to build. So if there is anything you don't like about this model, you can blame him.

If you do have comments, requests or suggestions, Richard is contactable at richard@wingnutwings.com

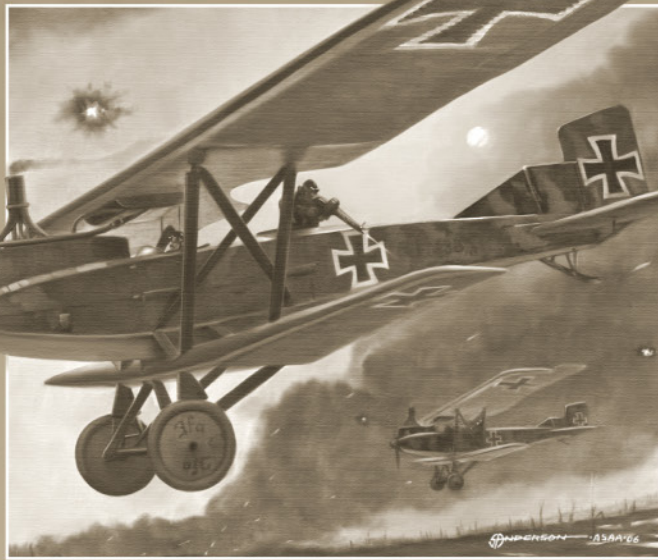

32001	1/32 Junkers J.1	Qty
0132001A	A parts	1
0132001B	B parts	1
0132001C	C parts	1
0132001D	D parts	1
0132001F	F parts	1
0132002H	H parts	1
0132001I	I parts	1
0132001P	Photo-etched metal parts	1
132E0001	E parts Benz Bz.IV	1
132G0001	G parts Parabellum LMG 14 and LMG 14/17	1
7132001	Instructions	1
9132001	Decals	1



32002 - 1/32 LVG C.VI



32003 - 1/32 SE.5a 'Hisso'



32004 - 1/32 Bristol F.2b Fighter

Available now from
www.wingnutwings.com

Wingnut Wings Ltd. PO Box 15-319 Miramar, Wellington 6243 New Zealand.
 All rights reserved. Designed in New Zealand - Manufactured in China.